

# LION

## LION: The perfect transformation of energy into efficiency

With 400 cuts per minute (with double blade) and a large insertion chamber measuring 350 x 240 mm (W x H), the LION slicing and portion cutting machine provides high capacity and sufficient space for numerous slicing applications.

It complements the portfolio of slicing and portion cutting machines by a broader, larger machine model that is especially suited for the supermarket and industrial target groups.



LION 700 F

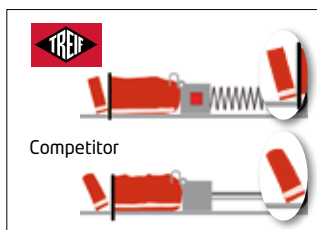

Competitor

Precise cutting results and evenly thick slices: the Dynamic Feeding System (DVS) allows synchronised slicing despite continuous product feed. The LION is equipped with the DVS as a standard.



Versatility is the hallmark of LION.

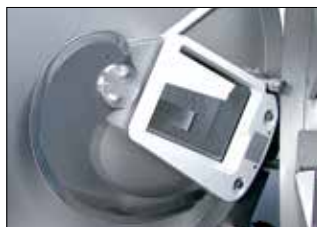

A look in the blade box shows a thin blade for a precise cut.



Whether bone-in or boneless - the portion cutting machine slices all products precisely and neatly.



The intelligent product feed holder can differentiate between meat and bone simply by gripping the product.



LION has a cutting output of 400 cuts/min. (with double blade).



The slices can be placed continuously or in packages.



The variety of products that LION can accommodate ranges from cutlets to cheese products.



## Versatile use of LION

LION can cut bone-in or boneless products such as bacon, pork belly, pork blade steaks, cutlets, beef steaks, roulades or cheese products.

Technical data:	LION F / FB	LION E / EB
Max. cut-off length (mm/inch)	0.5-70; 1/50"-2 4/5"	0.5-250; 1/50"-9 4/5"
Cuts per minute (double blade)	400	400
Cross-section of product w x h (mm/inch)	350 x 240; 13 4/5" x 9 1/2"	350 x 240; 13 4/5" x 9 1/2"
Max. Infeed length (mm/inch)	700; 27 3/5"	700; 27 3/5"
Housing dimensions (mm/inch)		
Length/Width/Height without belt (mm/inch)	1,890/1,150/1,550; 74 2/5"/45 1/2"/61"	1,890/1,150/1,550; 74 2/5"/45 1/2"/61"
Length/Width/Height with belt (mm/inch)	2,690 / 1,150/2,690 / 1,150/ 1,550; 106"/45 1/2" / 61"	2,690 / 1,150/2,690 / 1,150/ 1,550; 106"/45 1/2" / 61"
Connecting load (kW)	3.4/3.5	3.4/3.5
Products	Up to -4 °C /24.8 °F	Up to -4 °C /24.8 °F
Weight without belt (kg/lb)	320; 706	320; 706
Weight with belt (kg/lb)	409; 902	409; 902
Product specific accessories	on request	on request



Blades for various applications are optionally available (double, cordon bleu, crinkle blade, cheese and sausage blade).

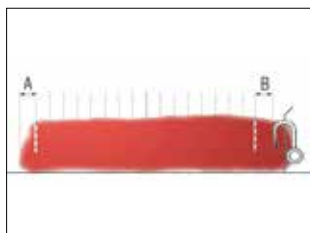

The residual piece optimisation ensures that the product is sliced in uniform thicknesses all the way to the residual piece.



Dimple plate: An air cushion forms between the dimples on which the product is effortlessly guided to the blade.

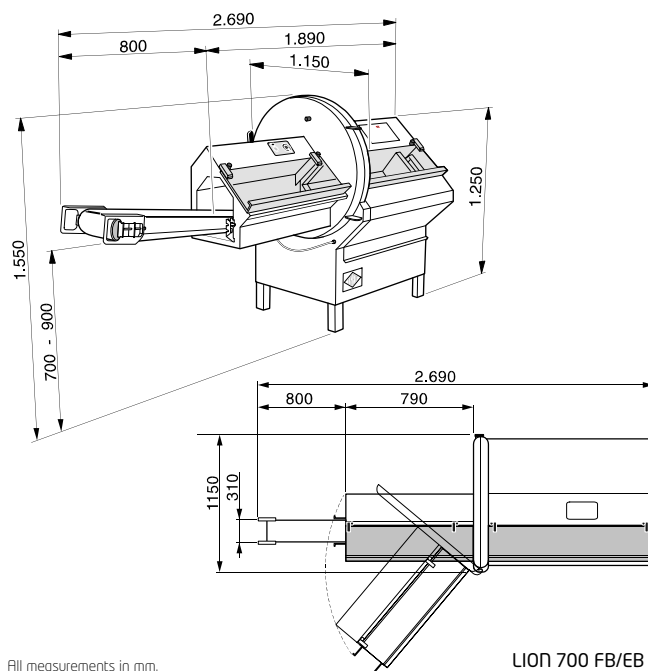

All measurements in mm.

LION 700 FB/EB

### Your benefits at a glance:

- The 350 mm-wide insertion chamber allows plenty of space for numerous slicing applications, particularly for bulky products
- High-performance and precision even with bone-in products
- Increased speed in the production as a result of the back-feed limitation
- Optimum utilisation of the product, for example by sectioning the product into slicing areas and as a result of residual piece optimisation (E/EB)
- Fulfilment of the highest hygiene requirements as a result of labyrinth guidance
- HS (High-Speed) more capacity (optional)

#### HEADQUARTERS:

TREIF Maschinenbau GmbH  
Toni-Reifenhäuser-Str. 1  
D-57641 Oberlahr  
Tel. +49 2685 944 0  
Fax +49 2685 1025  
E-Mail: info@treif.com

#### LOCATIONS:

TREIF USA Inc.  
50 Waterview Drive, Suite 130  
USA Shelton CT 06484  
Tel. +1 203 929 9930  
Fax +1 203 929 9949  
E-Mail: treifusa@treif.com

TREIF U.K. Ltd.  
Genesis House, Poole Hall Road,  
Poole Hall Industrial Estate  
Ellesmere Port, GB-Cheshire CH66 1ST  
Tel.: +44 (0) 151 3506100  
Fax: +44 (0) 151 3506101  
E-Mail: treifuk@treif.com

TREIF Italia S.r.l.  
Via Sant'Agnese 43-45  
40132 Bologna, Italia  
Tel.: +39 051 728138  
E-Mail: info.it@treif.com

TREIF S.A.R.L.  
22, rue des Tulleries  
F - 67460 Souffelweyersheim  
Tel.: +33 3 88184018  
Fax: +33 3 88184019  
E-Mail: info-france@treif.com

TREIF in Belgium  
Villalaan 21  
B-9320 Raalst  
Tel.: +32 53 770813  
Fax: +32 53 789666  
E-Mail: jo.luybaert@treif.com

TREIF Sp. z o.o.  
ul. Jana Kochanowskiego 49  
01-864 Warszawa  
tel: + 48 506 412 522  
service: + 48 506 413 197  
E-Mail: infopl@treif.com